



**FLORIDA RELAYS
PERCY BEARD TRACK
GAINESVILLE, FL
APRIL 6th – 7th, 2012**

FRIDAY, APRIL 6th SCHEDULE OF EVENTS:

FIELD EVENTS:

HIGH SCHOOLS

10:00am Long Jump (B & G)
Pole Vault (B)
Discus (G) outside field
Shot Put (B)
High Jump (G)

FIELD EVENTS

COLLEGIATE & OPEN

12:00pm Hammer (M) outside field
Discus (W)
1:00pm Long Jump (W)
2:30pm Discus (M) outside field
Javelin (M)
3:00pm Pole Vault (W)
Long Jump (M)
5:30pm High Jump (W)
Discus (W) Invite
Hammer (M) Invite
6:00pm Long Jump (W) Invite
7:30pm Javelin (W)
Long Jump (M) Invite

RUNNING EVENTS:

9:00am 3200m (HS-G)
9:30am 3200m (HS-B)
10:15am 1600m (HS-G)
10:40am 1600m (HS-B)
11:05am 800m (HS-G)
11:30am 800m (HS-B)
12:30pm 100 Hurdles (HS – G)
12:50pm 100 Hurdles (W)
1:15pm 110 Hurdles (HS -B)
1:35pm 110 Hurdles (M)
2:00pm 400m (W)
2:20pm 400m (M)
2:40pm 100m (HS – G)
3:00pm 100m (HS – B)
3:20pm 100m (W)
3:40pm 100m (M)
4:00pm 800m (W)
4:20pm 800m (M)
4:55pm 400m Hurdles (W)
5:15pm 400m Hurdles (M)
5:35pm Invite 200 (W)
5:50pm Invite 200 (M)
6:05pm 4x200 (HS – G)
6:25pm 4x200 (HS – B)

Evening Session

7:00pm Invite 800m (HS-G)
7:05pm Invite 800m (HS-B)
7:10pm Invite 1600 (HS-G)
7:20pm Invite 1600 (HS-B)
7:30pm Invite 3200 (HS-G)
7:45pm Invite 3200 (HS-B)
8:00pm 1500 (W)
8:20pm 1500 (M)
8:40pm Steeplechase (W)
8:55pm Steeplechase (M)
9:10pm 5000m (W)
9:30pm 5000m (M)

SATURDAY, APRIL 7th SCHEDULE OF EVENTS:

FIELD EVENTS:

HIGH SCHOOLS

10:00am Triple Jump (G & B)
Pole Vault (G)
Discus (B) outside field
Shot Put (G)
High Jump (B)

FIELD EVENTS:

COLLEGIATE & OPEN

11:00am Discus (M) Invite
11:30am Hammer (W)
1:00pm Pole Vault (M)
1:30pm Triple Jump (M)
2:30pm Shot Put (W)
Shot Put (M) Invite
4:00pm High Jump (M)
Triple Jump (W)
5:00pm Shot Put (M)
Shot Put (W) Invite

RUNNING EVENTS:

9:00 am 4x1600 (HS-G)
9:30am 4x1600 (HS-B)
12:00pm SMR (W)
12:15pm SMR (M)
12:30pm SHR (W)
12:45pm SHR (M)
1:00pm 4x800 (HS – G)
1:40pm 4x800 (HS – B)
2:20pm 4x100 (W)
2:45pm 4x100 (M)
3:10pm 4x100 (HS – G)
3:25pm 4x100 (HS – B)
3:40pm 4x800 (W)
3:55pm 4x800 (M)
4:10pm 4x200 (W)
4:30pm 4x200 (M)
4:50pm DMR (W)
5:10pm DMR (M)
5:30pm 4x400 (HS – G)
6:05pm 4x400 (HS – B)
6:40pm 4x400 (W)
7:05pm 4x400 (M)

SMR = Sprint Medley Relay (200-200-400-800)

SHR = Shuttle Hurdle Relay

DMR = Distance Medley Relay (1200-400-800-1600)

ENTRY NOTES – High School and Collegiate

- **All high school athletes must compete for their school! High school athletes will not be able to compete unattached for any reason!**
- Entries will only be accepted online via Direct Athletics at www.directathletics.com. Please contact support@directathletics.com if you have any questions. No fax or phone entries will be permitted.
- Entering your athletes is no guarantee of them being accepted into the meet. Check gatorzone.com on Saturday March 31 late Entries will be assessed a \$50.00 late fee per late entry and will be admitted on an individual basis.
- Any athlete participating in either individual or relay events must be on your team roster.
- Please remember to print out a confirmation sheet after you have entered all of your athletes in all of their events.
- Enter your athlete's lifetime best, indoors or outdoors, for relays (include a seasonal best or an estimated performance based upon your four athletes individual performances). **We will be verifying marks based on results in the FLRunners database as well as other sources provided.** Do not enter your athletes with marks that they have not achieved.
- Entry Deadline is **Wednesday, March 28th, 2012 @ 6:00PM.**
- All athletes accepted into the competition will be posted at gatorzone.com by 6:00pm Saturday, March 31st.

High School Sanctioning Info

The Florida Relays has submitted for sanction of an interstate athletic event to the National Federation of State High School Associations. The FHSAA has approved the Florida Relays for state of Florida association member schools.

Check with your state high school activities association if you have any questions before entering the Florida Relays. You can check for information on your state and Florida Relays sanctioning as www.NFHS.org/sanctioning.htm

CLUB & UNATTACHED INFORMATION

- Open competitors must be 18 years of age or older on April 7th, 2012. Unattached athletes may not wear a school uniform.
- **ENTRIES ON DIRECTATHLETICS.COM ONLY.** Deadline is Wednesday, March 28th, 2012.
- **ENTERING IS NO GUARANTEE OF BEING ACCEPTED INTO THE MEET.** Check gatorzone.com on Saturday March 31st, after 6pm to confirm your acceptance.
- No late entries will be accepted!

ALL ATHLETES NOT COMPETING WITH A COLLEGE MUST SIGN THE WAIVER OF LIABILITY AND HOLD HARMLESS AGREEMENT AND RETURN IT AT PACKET PICK-UP IN ORDER TO COMPETE

FLORIDA RELAYS TIMELINE

Wednesday	March 28 th - 6:00pm	Entries Due
Saturday	March 31 st - 6:00pm	Accepted entries posted on Gatorzone.com
Thursday	April 5 th – 4:00pm-7:00pm	Packet Pickup – Woman's Club
Friday	April 6 th – 7:00am-6:30pm	Packet Pickup – Woman's Club
Saturday	April 7 th – 7:00am-1:00pm	Packet Pickup – Woman's Club

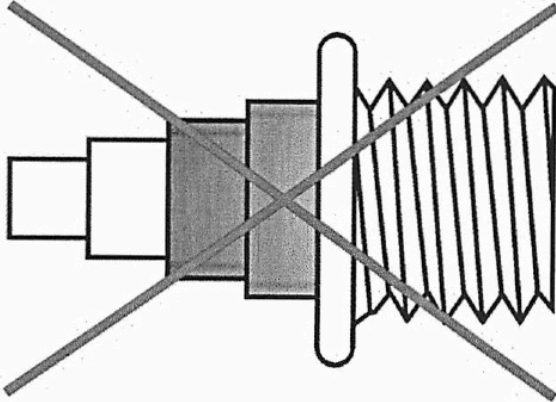

NO

**Christmas
Tree Spike
Pins**

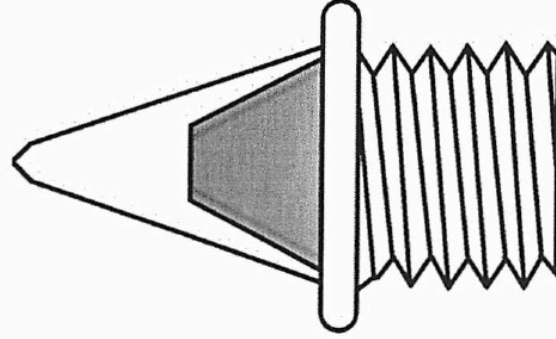

1/4"

Pyramid

Item #463A from
MF Athletics
800-693-6052

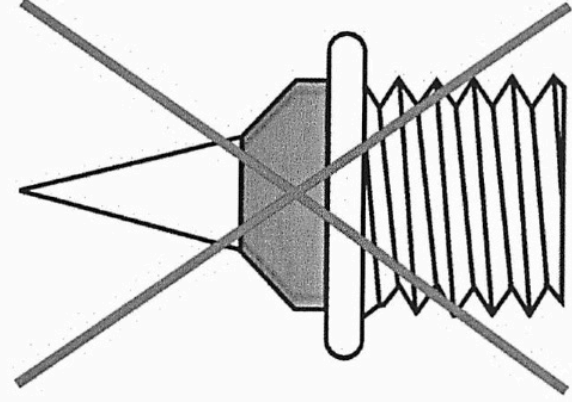

NO

**Needle
Spike
Pins**

ENTRY FEES – HIGH SCHOOL

There is an entry fee of \$10 per athlete, with a maximum of \$100 per team. Male and female teams are considered separate creating a maximum entry fee of \$200 per school. **All entry fees are non-refundable and non-transferable.** Entry fees are for the total number of athletes who qualify for the meet as of March 31st, 2012. Make sure to include all relay runners and alternates when you do your team roster online. **Entry fees must be paid at packet pick-up. Only accept cash and check.** Make checks payable to: *University Athletic Association.*

ENTRY FEES – COLLEGIATE / UNATTACHED

There is an entry fee of \$30 per athlete, with a maximum of \$300 per team. Male and female teams are considered separate creating a maximum entry fee of \$600 per school. \$5.00 for unattached athletes that show a valid college id. **All entry fees are non-refundable and non-transferable.** Entry fees are for the total number of athletes who qualify for the meet as of March 31st, 2012. Make sure to include all relay runners and alternates when you do your team roster online. **Entry fees must be paid at packet pick-up. Only accept cash and check.** Make checks payable to: *University Athletic Association.*

WEIGH-IN INFORMATION

Athletes must weigh-in all throwing implements at the track stadium in the northwest corner of the track (see posted sign). The weigh-in schedule is as follows. Implements which are not certified as official will be confiscated, and released following the competition.

IMPLEMENT WEIGH-IN SCHEDULES

Friday, April 6th, 2012:

8:00am – 9:30am

1:00pm – 3:30pm

Saturday, April 7th, 2012:

8:00am – 11:00am

12:30pm – 2:00pm

**Implements WILL NOT be accepted beyond times shown.
NO EXCEPTIONS!**

COLLEGIATE INFORMATION

- Athletes representing colleges/universities must be eligible according to the rules, which govern the athletic participation of their schools; i.e., NCAA, NAIA, or NJCAA.
- NCAA rules will prevail
- Each school may enter a maximum of three (3) individuals and two (2) relay teams per event except the 4x200 where a maximum of three (3) relay teams may be entered. Additional entries will not be accepted.

FIELD SIZES

<u>EVENT</u>	<u>NUMBER ACCEPTED</u>
Field Events	24
Open Track Events	45
100	63
4x1	54
4x2	36
SMR	27
Invite 200	24

Opening Heights and Minimum Measurements

Women:		Men:	
High Jump	1.60	High Jump	2.00
Pole Vault	3.65	Pole Vault	4.80
Long Jump	5.73	Long Jump	6.50
Triple Jump	11.50	Triple Jump	14.00
Shot Put	13.00	Shot Put	13.70
Discus	40.00	Discus	45.00
Hammer	45.00	Hammer	50.00
Javelin	35.00	Javelin	55.00

HIGH SCHOOL INFORMATION

- Athletes representing high schools must be eligible according to the rules, which govern the athletic participation of their schools; i.e., FHSAA.
- Each school may enter a maximum of two (2) individuals and one (1) relay team per event. Additional entries will not be accepted.
- Each athlete is allowed to participate in no more than 4 events, only 3 of which may be running events.

FIELD SIZES

<u>EVENT</u>	<u>NUMBER ACCEPTED</u>
Field Events	18
All other Events	All

Opening Heights and Minimum Measurements

Opening Heights and Minimum Measurements will be determined prior to the meet based upon the field accepted into the event.

GENERAL ANNOUNCEMENTS

▪ **PACKET PICK-UP**

Team/Individual packets will be available from the packet pick-up area at the Women's Club (located across the street behind the track stadium next to the basketball building). The packets will include meet information, athlete's numbers, pins, relay cards and a coach's pass. Packet pick-up times are as follows:

Thursday	April 5 th – 4:00pm-7:00pm	Packet Pickup – Woman's Club
Friday	April 6 th – 8:00am-6:30pm	Packet Pickup – Woman's Club
Saturday	April 7 th – 8:00am-1:00pm	Packet Pickup – Woman's Club

▪ **ENTRY INTO TRACK & FIELD STADIUM**

Athletes: Competitor number will admit athletes into the stadium.

Coaches: Coach's passes will admit coaches into the stadium. High school coaches will be given one coaches pass per athlete accepted up to six passes.

▪ **ADMISSION**

Admission is \$10 for adults, \$5 for children and \$1 for UF Students per day.

▪ **WARM-UP**

Competition Days: All athletes must complete their general warm-up outside the fenced track and field area.

Thursday April 5th the track will be open from 9:00am-1:00pm and 5:00pm-7:30pm for general warm-ups.

▪ **CHECK-IN PROCEDURE**

Athletes need to check into the Clerk of Course (NW corner of track) a minimum of one (1) hour prior to their scheduled event time. Heats will be assigned and seeded for Friday events Thursday evening and for Saturday events Friday Night. Scratches need to be done before this time following below guidelines.

▪ **PREFERRED LANES**

For the 200 and all other oval races conducted in lanes, the order of preferred lanes is 6, 7, 5, 8, 4, 9, 3, 2, 1.

▪ **ATHLETE'S NUMBERS**

Athlete's numbers will be worn on the front for all events except the pole vault.

▪ **COACHING**

No coaches will be allowed in the fenced track & field areas. Athletes competing in the field events may leave the field to consult with their coach, if it does not interfere with the competition. Coaches will be allowed in the field event area, outside the fence near McKethan Baseball Stadium.

▪ **FIELD EVENT CONDUCT**

LJ/TJ/SP/D/J/HT competitors will receive three (3) attempts with the top nine (9) athletes advancing to the final, to receive three (3) additional attempts. Each field event contestant must have a legal mark to receive additional attempts. The HJ/PV will be contested in continuous flights.

▪ **HIGH SCHOOL DISTANCE RACES**

Lapped runners in the 4x1600m relay and 3200m will be pulled from the track down to 12 teams.

▪ **FALSE STARTS**

The No False Start rule will be in effect.

- **PROTEST**

Protests must be filed, in writing, at the clerk tent no later than 30 minutes following the involved incident or decision.

- **FACILITY**

Mondo Surface: 9-48" lanes; double field event areas in long and triple jump, high jump, shot put, discus, and pole vault; maximum length of spikes - 1/4" pyramids. **Needle/Pin or Christmas Tree Spikes Will NOT Be Allowed.**

- **AWARDS**

The winner in all Running and Field Events will receive an award. Awards can be picked up in the Pressly Press Box following the posting of the events results.

- **TRAINING AREA**

A large tent for athletic trainers will be set up in the southwest corner of the stadium.

- **RESULTS**

Results will be posted under the south end of the stadium, on gatorzone.com, and deltatiming.com as soon as possible.

- **SCRATCHES**

Scratches are appreciated and can be emailed to mellaneew@gators.ufl.edu.



FOR MORE INFORMATION:

E-mailing will get a quicker response. Please only contact one person.

For questions regarding entries, acceptance and deadlines e-mail:

Mellanee Welty MellaneeW@gators.ufl.edu

For questions regarding Sanctioning, Entry fees and General Info contact:

Therese LeGrow 352-375-4683 ext. 4400

Theresel@gators.ufl.edu

***After Tuesday, April 3rd at 5:00pm correspondence needs to come via e-mail only.**

